

State-of-the-art technology from A to Z: innovations from Pfiffner

Hydromat® rotary transfer machines

Tools

CNC systems

Innovative ways of thinking and operating from Pfiffner: for entrepreneurs with vision

When your objective is to satisfy the demands placed on the workpieces of tomorrow, you need the iron discipline required to develop new technologies, new machines, new tools, new machining processes and new approaches to thinking. Only by adopting this attitude can we develop and launch the Hydromat® rotary transfer machines that keep our customers a step ahead of the competition.

And that's the reason why Pfiffner's future also lies in its past. Ever since our company's foundation, we have continually invested time and money in the research, development and manufacture of rotary transfer machines that all pursue the same goal: the production of

- ever more complex workpieces
- with ever-greater precision
- in ever-shorter cycles.

At Pfiffner, this is the only working process that never comes to an end. With the result that our innovations go on making small, medium-sized and large enterprises all over the world more productive and efficient.



Innovative Hydromat® rotary transfer machine design for more reliability in production

Hydromat® rotary transfer machines were developed to deliver maximum performance 24 hours a day, seven days a week. Even the design of each of the machines features innovations that seek their equal:

- Space-saving hydraulic systems.
- All electric cables and components are safely positioned outside the machining areas.
- Smart swarf removal increases productivity and prevents damage to workpieces.
- Workpieces can be measured during the machining process and any necessary adjustments carried out automatically. The control system automatically applies corrected data to the next piece.
- Difficult materials, such as forged metals and stainless steels generate long pieces of swarf when turned. This

can impede the production process. With the Hydromat® we can use milling technology instead of the turning process.

All these features ensure that Hydromat® rotary transfer machines offer unmatched standards of production reliability.



Innovative Hydromat® rotary transfer machine technology for maximum precision

The increasing complexity of precision workpieces calls for matching complex processes. This is the reason why Pfiffner has designed a special pick-up technology to facilitate the concentric machining of a workpiece from two sides.

The fact the workpiece rotates in the pick-up unit means concentricity of a precision never previously achieved.

- In principle, the pick-up unit is a rotating cell integrated in the machine
- Thanks to the rotating cell, the machine is able to work with both stationary tools and rotating workpieces.
- The pick-up unit removes the workpiece from the collet on the index table, clamps it on the side that has already been machined and presents the side still to be processed to the tool.
- This permits the machining of cup-shaped pieces, for example, with concentricity on the opposite side accurate to 0.02 millimetres.



Innovative tools and machining units for more efficiency

Depending on the demands placed on the workpiece being produced, the tools previously used in the machining of symmetrical, round or cubic parts, of blanks or circular materials from bars were either very simple or highly complex. And that necessitated a whole host of adapters.

Today, CNC permits the use of simple tools for all machining operations. In fact, even complex contours can be cut using standard tools. Standard tools and standard machining units such as

- drilling, milling, cross-drilling, turning, tapping, rolling and chasing heads;
- recessing and inclined slide heads for internal and external applications;
- feed, thread, recessing and inverting units;

- CNC correction and control units.

As every standard tool can be used with every machining unit, the cost of expensive customized production is eliminated and cost-effectiveness increased.



Innovative computer numerical control for increased flexibility and productivity

With workpieces becoming ever more complex and the materials and alloys involved increasingly valuable, it takes sophisticated software to keep pace with highly developed hardware. In other words, CNC:

- All data can be keyed into the display. Mechanical setting is a thing of the past.
- User-friendly handling eliminates sources of error and reduces waste to an absolute minimum.
- Older rotary transfer machines can be retrofitted with CNC at any time.
- Thanks to CNC technology, retooling from one workpiece to another is completed very quickly.
- CNC technology permits continuous monitoring and testing of machining processes. The actual dimensions of the workpiece are subjected to

on-going comparison with prescribed specifications at every stage and corrected where necessary.

- With CNC technology, it is absolutely no problem to machine difficult surfaces with complicated contours.
- Hydromat® rotary transfer machines from Pfiffner that have been equipped with CNC technology can handle simultaneous interpolation with up to four axes at a single station.

So, as you can see, a Siemens CNC system is designed to get the best out of a Hydromat® rotary transfer machine from Pfiffner.

Innovative machining processes for higher profitability

At Pfiffner, the whole is also more than the sum of its parts. Because innovative design, technology, tools and control systems make machining processes possible that are revolutionizing the industry.

- One outstanding milestone from Pfiffner was the x-y flange, allowing the machining process in three axes on a single unit.
- Another is quadruple-axis machining of the workpiece with a single unit.
- Milling, drilling and tapping together with complex thread-whirling and polygon turning in a single cycle.
- Thread-milling, complex 3D contour-milling, maximum-precision broaching instead of turning.

With our state-of-the-art, CNC Hydromat® rotary transfer ma-

chines we have taken up the challenge of producing increasingly complex workpieces. And are using them to make enterprises more economical and more profitable.





The ultimate
in industrial production:
Innovations from Pfiffner

Creation

Implementation

Production

Innovation is the principle behind our business

The Latin word “innovatio” means renewal. At Pfiffner, we define renewal as the change to higher efficiency, greater precision and more quality.

We believe anyone with an aspiration to leave a lasting mark on industrial production first of all needs to understand his clients’ business. And that means:

- knowing the markets in which they are active
- recognizing the challenges that face them
- understanding how they can set themselves apart from the competition.

Only in this way is it possible to make Hydromat® rotary transfer machines with CNC systems that genuinely meet the needs of clients and their markets.

For us, this has been reason enough to elevate the ongoing further development of our products and services to the status of a business principle. And to do all we can to ensure that you and your company benefit from our innovations. Today, and in the years to come.

On the following pages, we would like to show you some of the highlights born of the close relationships we tend with our clients.

Innovative solutions from Pfiffner

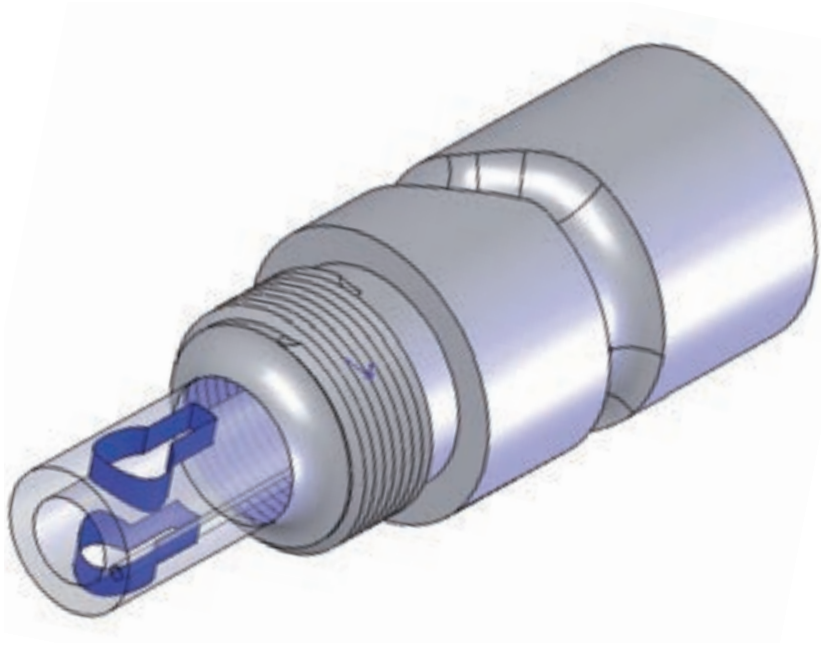

Nibbling/Broaching

Numerically controlled double-sided slotting operation at up to 600 strokes per minute.

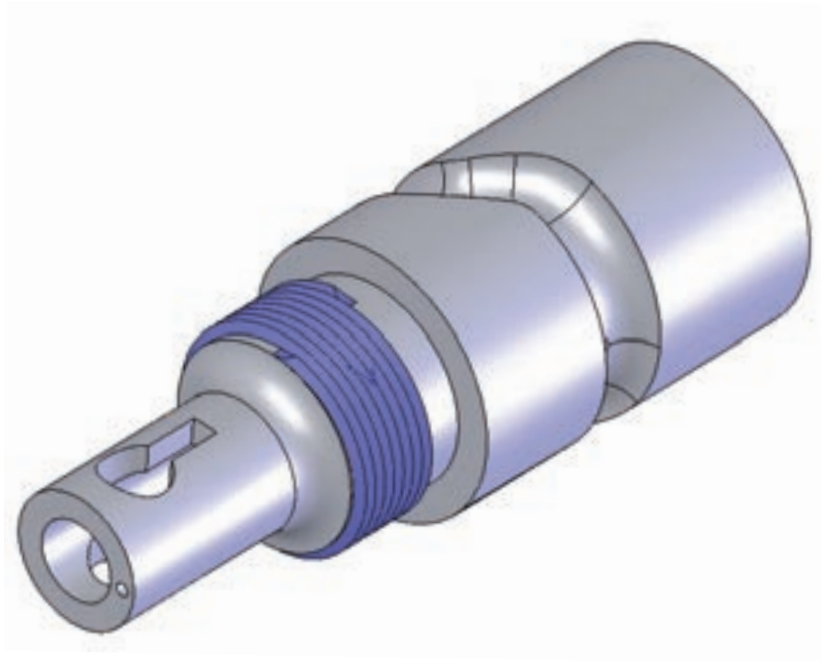

Circular milling

Applications:

- thread milling of internal and external threads
- milling of complex internal and external contours (free forming)
- milling of internal and external recesses (making it easier to control swarf on materials that are difficult to cut)

Technology:

Numerically controlled X/Y/Z flange.

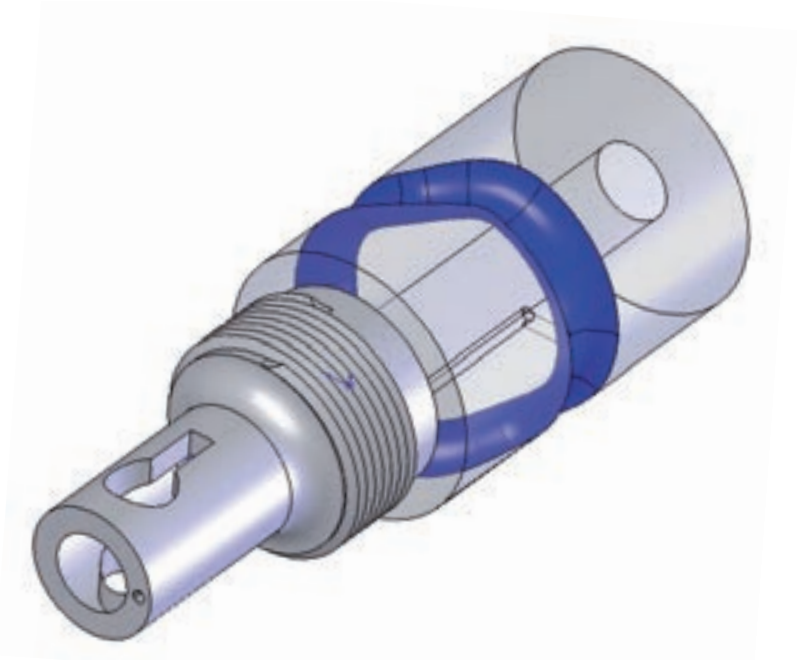

Helical milling

Applications:

- milling of freely programmable threads
- Cross hole drilling in any relative position
- complex deburring operations
- freely programmable four-axis interpolation

Technology:

Numerically controlled X/Y/Z flange with additional C axis.

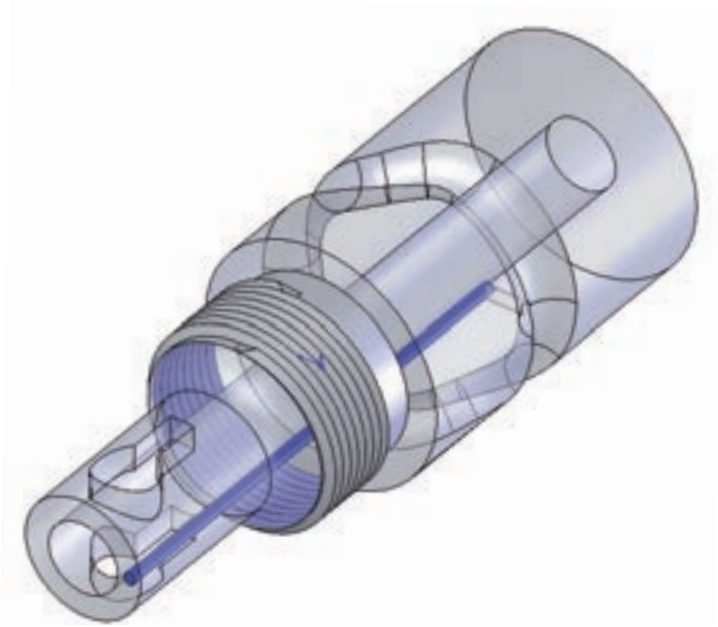

Deep hole drilling

Applications:

- Deep hole drilling from approx. 1 mm

Technology:

- Speeds of up to 28 000 rpm
- High pressure up to 180 bar
- Stroke up to 120 mm



Head offices:

K.R. Pfiffner AG

Gewerbestrasse 14

P.O. Box 229

CH-8800 Thalwil

Switzerland

Tel.: +41 44 722 66 66

Fax: +41 44 722 66 77

info@pfiffner.com

www.pfiffner.com

K.R. Pfiffner GmbH

Axtbühl 2

D-78658 Zimmern o.R.

Germany

Tel.: +49 741 92 88 0

Fax: +49 741 92 88 155

info@pfiffner.de

www.pfiffner.com